



Description

Bullet Nose insert for use in confined areas.

Insert Selection: Most inserts are available in three grades of material- standard, heavy duty and Tungsten Carbide tipped. Under normal use in a cost basis, the most expensive grade will give the best cost versus insert life (i.e. carbide is better than heavy duty, is better than standard). Concave face permits easy wire entry. Flat face permits better stripping flush to coil body. Bullet nose permits stripping in confined areas

Specifications

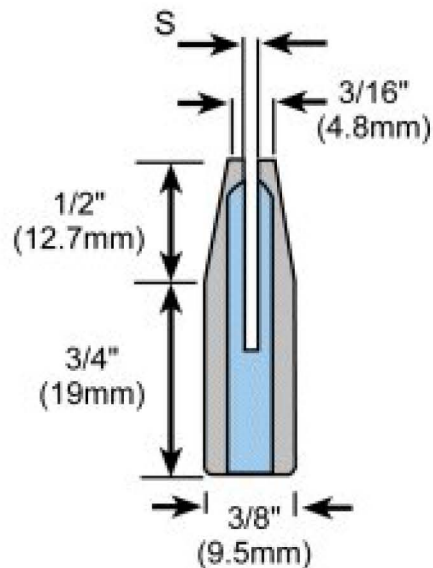

"S" dimensions are determined by wire size to be stripped

Wire Size	AWG: 24-20 (0.51 - 0.81mm \varnothing)
Grade	Carbide Tipped
Shape	Bullet Nose
Compatible Models	L1, L2S, IR0104, L4, PL3S Note: L1, L2S, PL3S and L4 inserts [3/8" (9.5mm) diameter] are the same but not interchangeable with L2AS and L4A inserts [1/2"(12.7mm) diameter].