



**southco**

PROPRIETARY ITEM - EXCEPT FOR USES EXPRESSLY GRANTED IN WRITING INFORMATION DISCLOSED HEREON IS CONFIDENTIAL AND ALL RIGHTS PATENT AND OTHERWISE ARE RESERVED BY SOUTHCO, INC.

**SOUTHCO No. 47 CAPTIVE FASTENER  
10-32 THREAD, FLARE-IN STYLE**

DATE	DRAWN	CHKD	SCALE	DRAWING NUMBER
5/23/91	JAD		2 : 1	J-47-1-132

REV.	DATE	DRAWN	REVISION	PART NUMBER	SCREW PROJECTION			PANEL THICKNESS		*B*	*L*	DIMENSIONS IN INCHES DIMENSIONS WITHOUT TOLERANCES ARE FOR REFERENCE ONLY
A	B	C	D	E	F	G	A, MIN	A, MAX				
A	15JUN93	MPF	PRN: 47-136		*P1*	*P2*	*T*					 THIRD ANGLE PROJECTION  A3 PAPER SIZE
B	12APR93	ALC	PRN: S-1-03	47-10-5X2-YZ	.05	.25	.66	.058	.125	.015	.070	
C	25APR96	KGS	PRN: 47-213	47-10-5X4-YZ	.11	.31	.73	.126	.187	.062	.135	
D	14JUL98	AJH	PRN: 47-325	47-10-5X6-YZ	.17	.37	.79	.188	.250	.125	.197	
E	30JUN99	RJB	PRN: 47-447	47-10-5X8-YZ	.24	.44	.85	.251	.312	.187	.260	
F	27AUG2001	RJB	PRN: P2001-0454	47-11-5X2-YZ	.11	.31	.73					
G	23APR2002	JPA/DLH	PRN: P2002-0237	47-12-5X2-YZ	.17	.37	.79	.058	.125	.015	.070	
MATERIAL AND FINISH				47-13-5X2-YZ	.24	.44	.85					
KNOB: 6000 SERIES ALUMINUM, NATURAL.				47-11-5X4-YZ	.17	.37	.79	.126	.187	.062	.135	
SCREW:				47-12-5X4-YZ	.24	.44	.85					
FOR SLOTTED AND PHILLIPS:				47-11-5X6-YZ	.24	.44	.85	.188	.250	.125	.197	
400 SERIES STAINLESS STEEL, PASSIVATED.												
FOR TORX® TORX®/SLOT COMBINATION												
AND PHILLIPS/SLOT COMBINATION:												
HARDENED CARBON STEEL; ZINC PLATE,												
CHROMATE PLUS SEALER												
(NOTE: KNOB AND TOP OF SCREW AVAILABLE WITH												
POWDER COATING; SEE PART NUMBER TABLE)												
FERRULE: 6000 SERIES ALUMINUM, NATURAL.												
SPRING: 300 SERIES STAINLESS STEEL; PASSIVATED.												

TORX® IS A REGISTERED TRADEMARK OF THE CAMCAR DIVISION OF TEXTRON, INC.

**"X" SCREW RECESS**

- 0- SLOTTED
- 2- No.2 PHILLIPS
- 4- T25 TORX®
- 6- T25 TORX® SLOT
- 8- No.2 PHILLIPS SLOT

**"Y" FINISH ON KNOB & SCREW HEAD**

- 1- BRIGHT
- 4- CUSTOM COLOR. SEE J-47-0-3 FOR ADDITIONAL SUFFIX.
- 5- BLACK POWDER COATED

**"Z" KNOB**

- 0- KNURLED
- 1- SMOOTH

**KNURLED KNOBS**

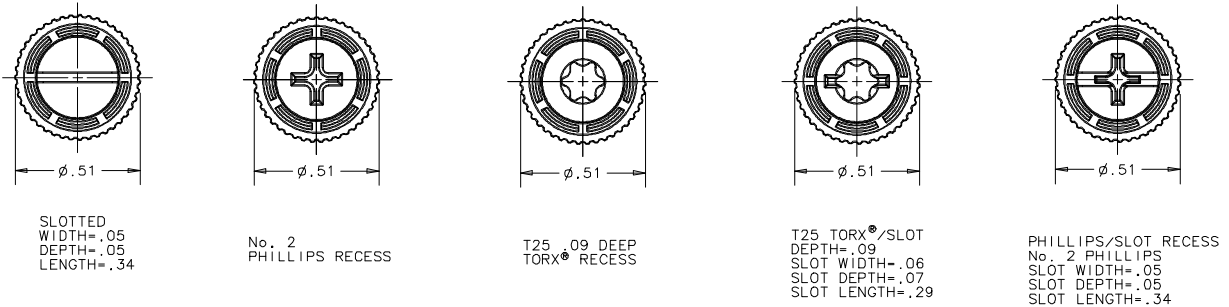

**SMOOTH KNOBS**

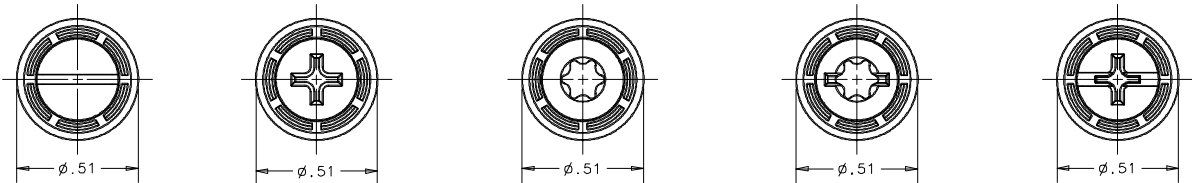

NOTE: KNOB AND SCREW ARE SPRING LOADED OUTWARD, AS SHOWN BELOW.

**TO INSTALL FASTENER**

1. DRILL, THEN COUNTERSINK ACCORDING TO THE REQUIRED \*B\* DIMENSION.
2. INSTALL TOOL PART No. 47-110 IN SUITABLE PRESS. ONLY LIGHT PRESSURE WILL BE REQUIRED.
3. INSERT SCREW ASSEMBLY INTO PREPARED HOLE IN PANEL.
4. PLACE WORK UNDER PRESS, CENTER TOOL OVER SCREW THREAD AND FLARE FERRULE INTO COUNTERSINK IN PANEL. USE LIGHT PRESSURE.

INSTALLATION FORCE: 350 lbs. TO 550 lbs.  
INSTALLATION FORCE DEPENDS ON THREAD SIZE.

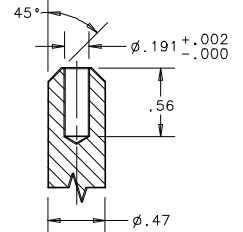

FLARE INSTALLATION TOOL GEOMETRY  
SCALE 1:1

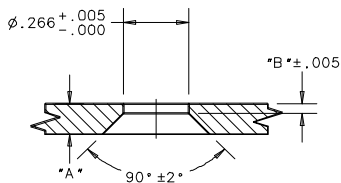
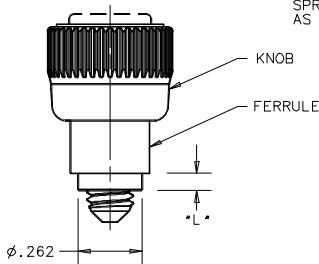

**PANEL PREPARATION**

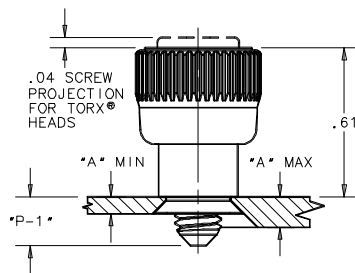

**UNFASTENED**

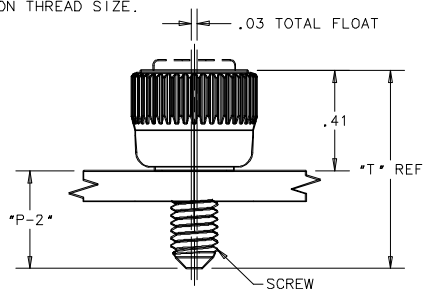

**FASTENED**